



TOOLHOLDER INSTRUCTIONS

Thank you for choosing our products.
For best results, please follow below instructions.

GENERALITIES

Each toolholder has passed quality control testing and is supplied with documented specifications confirming its geometric accuracy.

Each toolholder is checked for temperature and vibration parameters on the automatic test bench. This means that the toolholder is ready to start working in the production process!

PLEASE NOTE

Keep these instructions, with care, to have them whenever needed for consultation.

Be aware of any state law to avoid accidents for yourself and others by using live toolholders. Be careful when handling the toolholder to prevent it from falling, which could cause injury to yourself and others. Until the toolholder is attached to the turret, use rubber or plastic tool sleeves to avoid injuries caused by the tool cutting sharp edges.

If the toolholders are overloaded, there may be major damage in the operation of the product. This brochure contains symbolic representations. Some accessories shown are not included as standard with the delivered toolholders.

1. INSTALLATION AND SETUP

1.1. Toolholder setup

To ensure optimal toolholder performance, the turret interface and coupling surfaces must be clean. Only this guarantees the highest possible accuracy during the cutting process.

1.1.1. Toolholder mounting on the turret

Please inspect the contact surface of the turret. It must be clean and without chips.

Please check that the O-ring (1) is not damaged.

Insert the toolholder shank into the turret bore, rotating the toolholder spindle until the drive coupling (3) engages with the turret drive. Ensure that the coolant ports (2) on both the toolholder and the turret are aligned. Continue inserting the toolholder until the interface contact with the turret is fully established. Finally, firmly tighten the toolholder using bolts (4) with the hex key (5).

The term BMT (Bolt Mounted Turret) refers to the mounting system illustrated at position (4), where the toolholder is directly fixed to the turret using bolts.

The majority of our toolholders are equipped with POLYFLEX drive couplings (3), which accommodate slight turret misalignment and reduce vibrations transmitted from the lathe to the cutting tool.

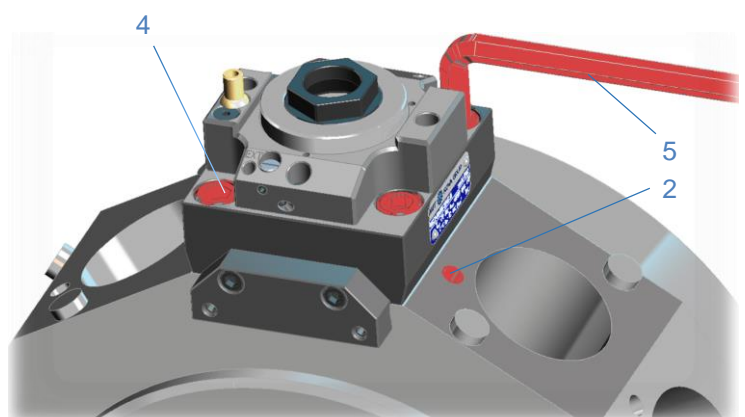
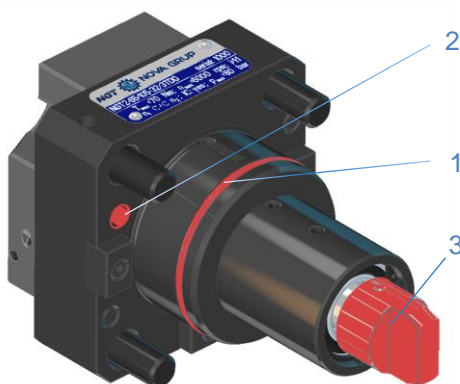

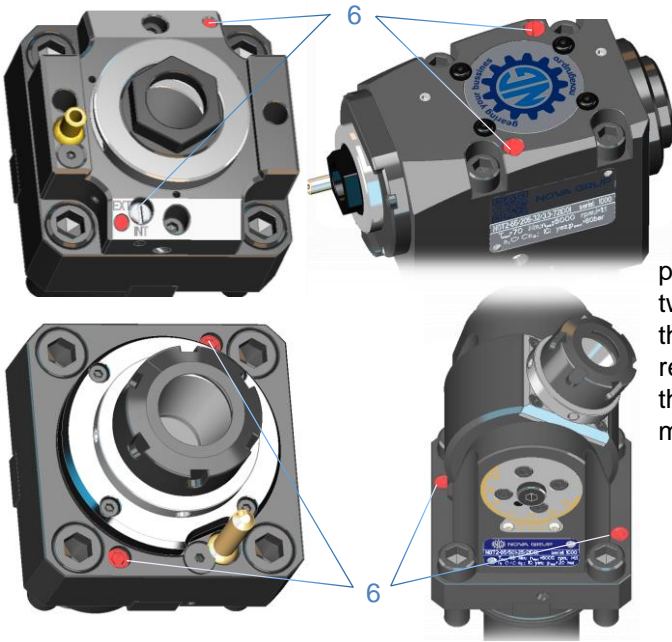

For removal from the turret, the toolholders are provided with two extraction screws (6). Tighten the two screws alternately using a suitable hex key until the toolholder is released. After removal, make sure to return the extraction screws to their initial position so that their ends remain below the level of the turret mounting surface.

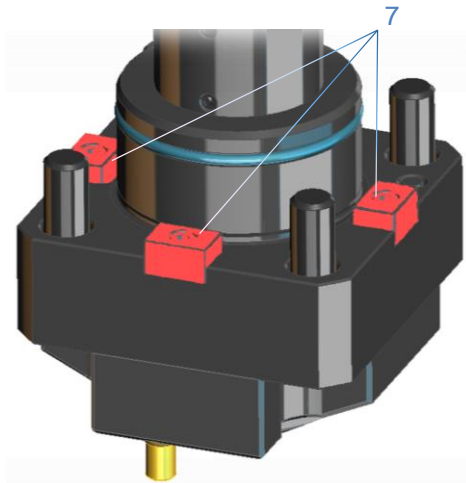

1.1.2. Toolholder alignment

BMT toolholders are generally centered and aligned by means of the turret bore diameter and the keyways or alignment keys (7) located on the turret mounting surface. Accordingly, the toolholders may be equipped with alignment keys or alignment keyways and are automatically centered without operator intervention. An exception applies to BMT60 toolholders for OKUMA turrets.

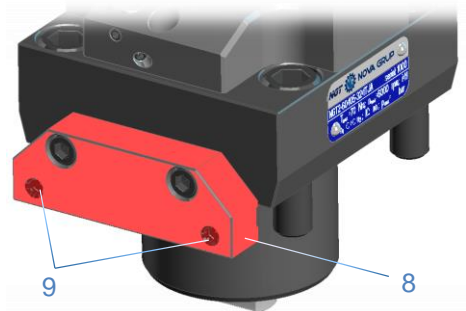

1.1.3 Centering plate system is used on OKUMA turrets. The centering plate (8) comes into contact with the front face of the turret. It is equipped with two threaded pins for fine adjustment or for alignment in the case of turrets with positional deviation.

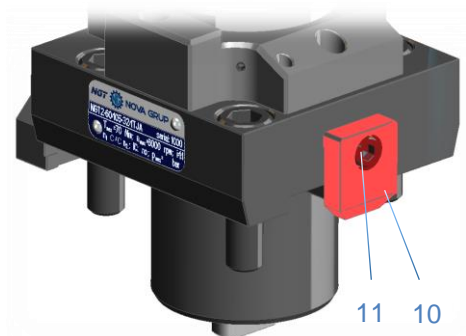

Alignment procedure

1. Place the toolholder on the turret and lightly tighten the four mounting screws.
2. Tighten the clamping plate (10) using screw (11).
3. If necessary, adjust the toolholder position using the threaded pins (9).
4. Finally, fully tighten the four mounting screws.

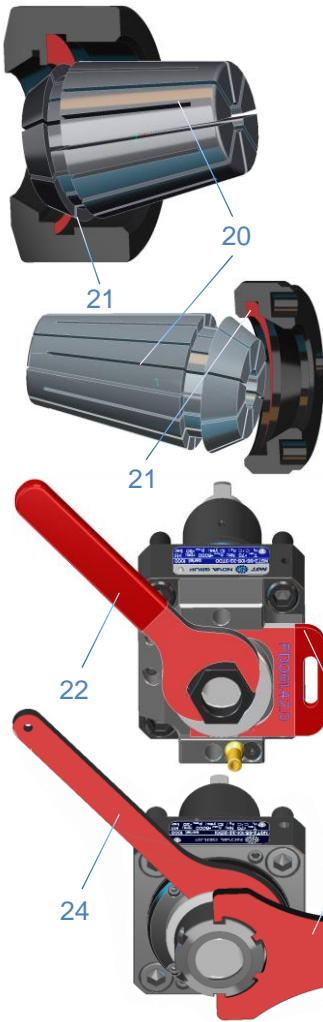

1.2. Clamping the tool

1. Insert the collet (20) at a slight angle into the ER clamping nut (21) until it engages in the locking groove
2. Insert the collet and nut assembly into the inner taper of the toolholder shaft
3. Firmly tighten the ER clamping nut using two keys (22)(23) or (23)(24) as in below pictures.

1.3 Toolholders coolant system

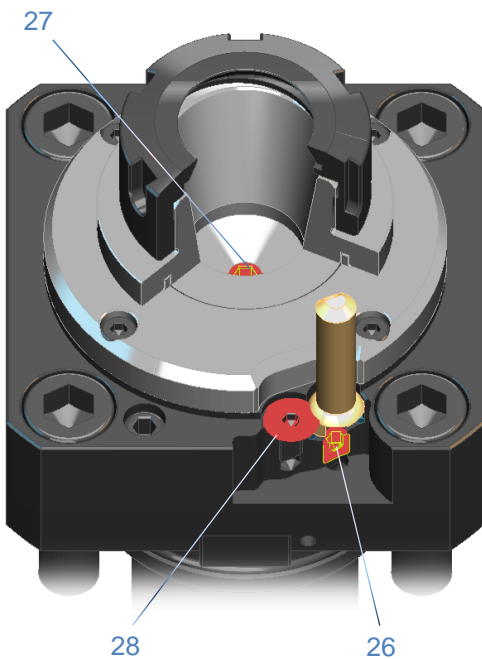

1.3.1 Straight 20 bar internal cooling toolholder is factory prepared for this option. Toolholders supplies coolant through the shaft, to the cutting tool.

To activate external cooling:

1. Remove plug (26) using a hex key
2. Install plug (27).

To reactivate internal cooling:

1. Reinstall plug (26)
2. Remove plug (27).

To access plug (26), loose screw (28) until it released and remove the adjustable nozzle. The adjustable nozzle is sealed with an O-ring. Check that it is in place.

If both plug (27) and (26) are removed, the toolholder operates in both modes, internal and external cooling.



Never operate the toolholder without coolant.

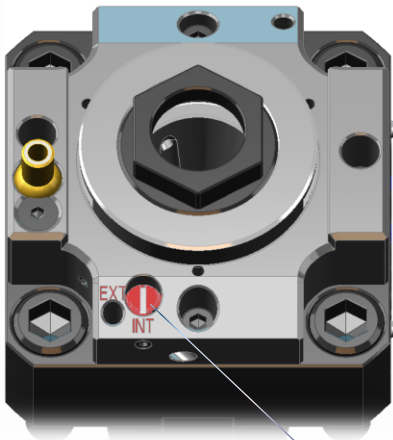

29

1.3.2 Straight 80 bar internal cooling toolholder is factory prepared for this option. Toolholders supplies coolant through the shaft, to the cutting tool.

To activate external cooling, use a screwdriver to align the notch on the distributor (29) with the EXT mark. To reactivate internal cooling, reposition the notch on the distributor so that it aligns with the INT mark.



Dry running is permitted under specified operating conditions.

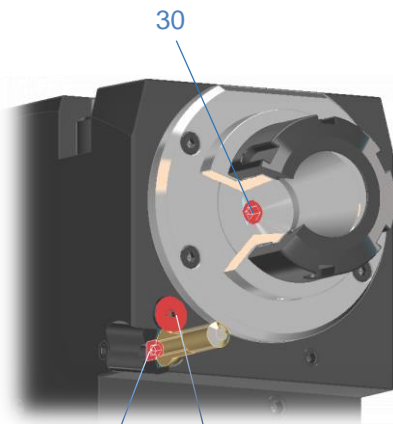

31

32

1.3.3 Angular 20/80 bar internal cooling toolholder is factory prepared for this option. Toolholders supplies coolant through the shaft, to the cutting tool.

To activate external cooling:

1. Remove plug (31) using a hex key
2. Install plug (30).

To reactivate internal cooling

1. Reinstall plug (31)
2. Remove plug (30).

To access plug (31), loose screw (32) until it released and remove the adjustable nozzle. The adjustable nozzle is sealed with an O-ring. Check that it is in place.

If both plug (30) and (31) are removed, the toolholder operates in both modes, internal and external cooling.

Same procedure applies to angular offset toolholders.



Never operate the toolholder without coolant..

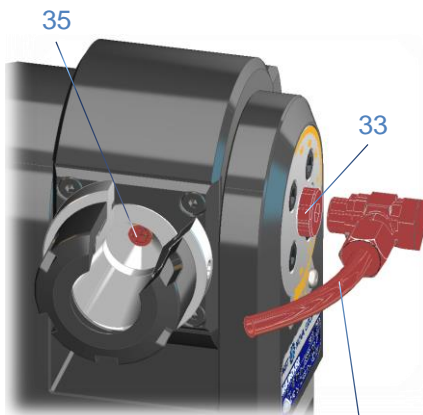

35

33

34

1.3.4 Variable angle internal cooling toolholder is factory prepared for this option. Toolholders supplies coolant through the shaft, to the cutting tool.

To activate external cooling:

1. Remove threaded plug with O-ring (33) using a hex key
2. Install 90° degree elbow fitting with copper tube (34)
3. Install plug (35).

To reactivate internal cooling:

1. Reinstall plug (33)
2. Remove plug (35).

If plug (35) is removed and the 90° degree elbow fitting with copper tube (34) is installed, the toolholder operates in both modes, internal and external cooling.



Never operate the toolholder without coolant..

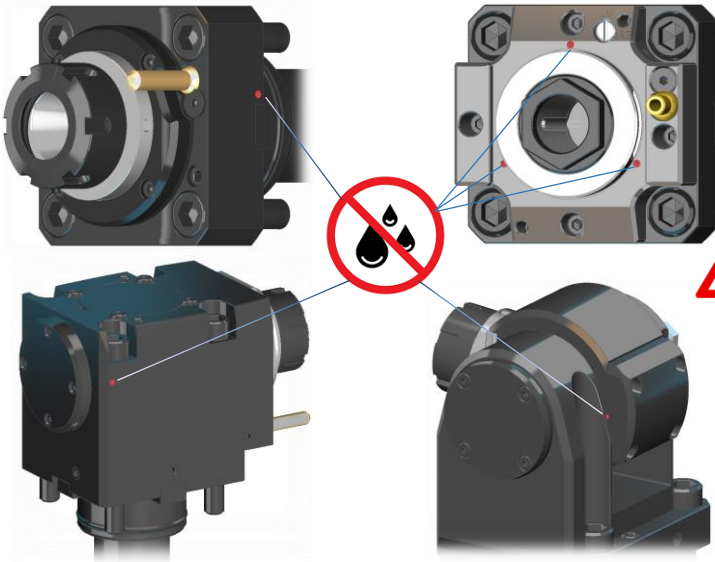

If coolant leakage is detected during operation of the toolholder, stop using the toolholder immediately and contact the manufacturer or authorized dealer.

2. OPERATION

The diagram below, helps determine the appropriate working cycle based on the percentage of the maximum permissible speed at which the toolholder is operated.

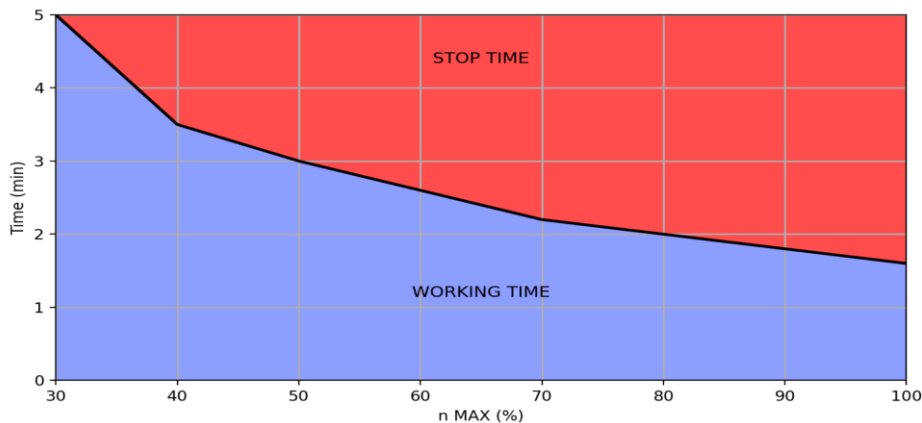

The diagram below illustrates the required reduction of the maximum permissible torque depending on the machining type and load condition.

The vertical axis shows the reduction of the maximum torque (%), while the horizontal axis groups different machining applications into Light, Normal, and Hard load conditions.

The boundary line defines the recommended operating limit. The blue area (below the line) represents the permissible operating range.

The diagram ensures safe tool operation by compensating for increasing impact loads and dynamic stresses associated with more demanding machining processes.

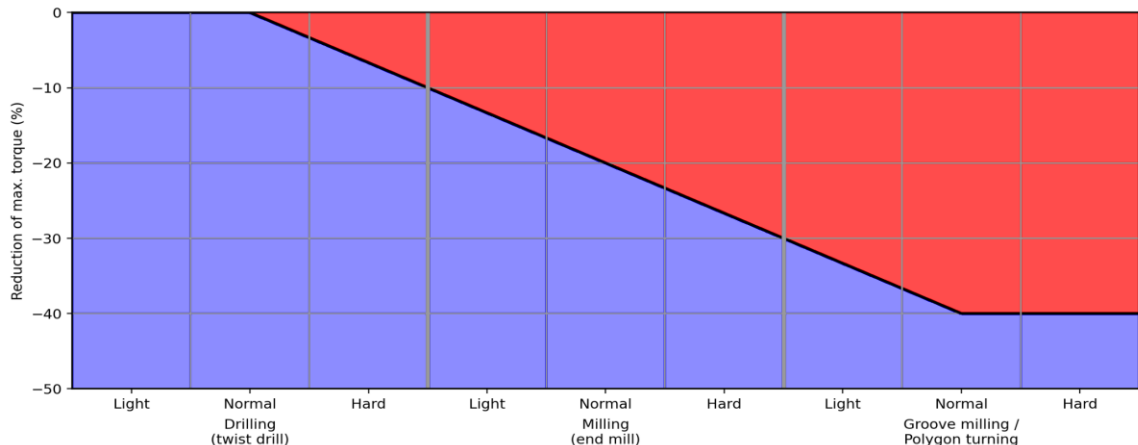

The diagram below shows the relationship between spindle speed and the coolant pressure. The vertical axis indicates the coolant pressure (bar) while the horizontal axis represents the speed (rpm).

The straight boundary line defines the recommended operating limit. Operating outside the blue range may negatively affect tool life and machining performance.

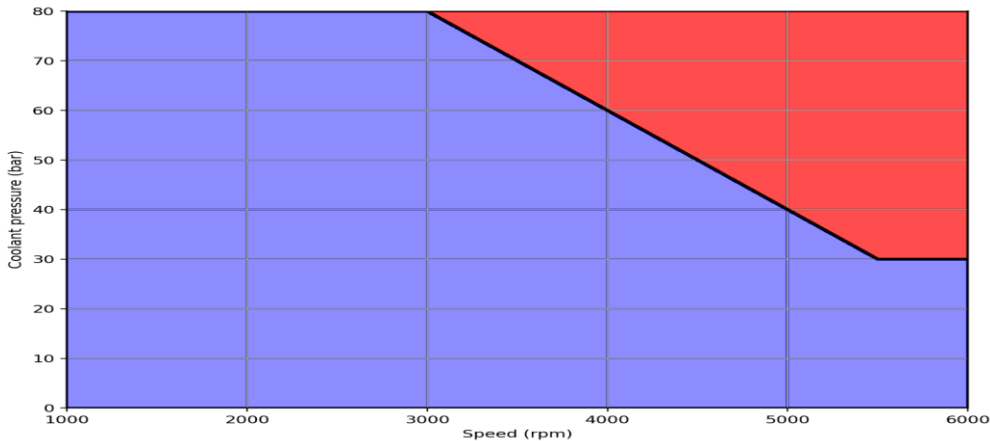

3. EVENTS DURING OPERATION

If a malfunction occurs during operation, the lathe operator must immediately stop using the toolholder to prevent further damage or unsafe conditions. The customer shall notify the manufacturer or authorized dealer without delay and submit a completed **Service Request Document**.

If problems or malfunctions occur, contact the manufacturer or authorized dealer and return the product for inspection together with the completed Service Request Document.

The Service Request Document is available on our website in the “**Service**” section.

3.1. Return Conditions and Instructions:

To ensure efficient handling and the shortest possible repair time, the following conditions must be observed:

All products may be returned only after prior approval from the manufacturer or an authorized dealer.

Before returning the product, the customer must:

- notify the manufacturer or authorized dealer in advance
- propose a delivery date so that the repair or evaluation can be scheduled accordingly

All returned products must:

- be properly packaged to prevent damage during transport
- be accompanied by a fully completed **Service Request Document**
- include a detailed and accurate description of the problem, including relevant operating conditions and application data

Products received without a completed Service Request Document or with insufficient information may be processed with lower priority or may lead to delays in diagnosis and repair.

3.2. Return of Goods Due Incorrect Order:

In the event of an incorrect order placed by the customer, return of the product requires prior approval from the manufacturer or authorized dealer.

If the return is approved:

- the manufacturer will agree with the customer on replacement or appropriate corrective action
- all transportation and related costs shall be borne by the customer

The manufacturer reserves the right to reject returns that do not comply with the above conditions.

4. CLEANING AND CARE

Clean the toolholder using a soft cloth.

Do not use compressed air, as this may damage internal components.

Do not use aggressive or chemical cleaning agents.

During storage, protect all surfaces with oil or suitable anti-corrosion products.

Proper cleaning and storage contribute significantly to product lifetime.

Before storage, ensure that all internal coolant channels of the toolholder are free from coolant residues, as non-compliant coolant emulsions may lead to corrosion inside the toolholder.



5. MAINTENANCE

Ball bearings and gears are lubricated with high-quality lubricants designed for lifetime operation.
For toolholders equipped with tapered roller bearings:



Use the designated lubrication points and apply SKF LGNL 2 grease or equivalent. For angular and offset toolholder versions, the gears are lubricated with Thermoplex ALN 251 grease. Under normal operating conditions, no additional lubrication is required.

However, for toolholders equipped with an inspection cover or grease plug, relubrication is recommended after 24 months using approximately 25 g of grease

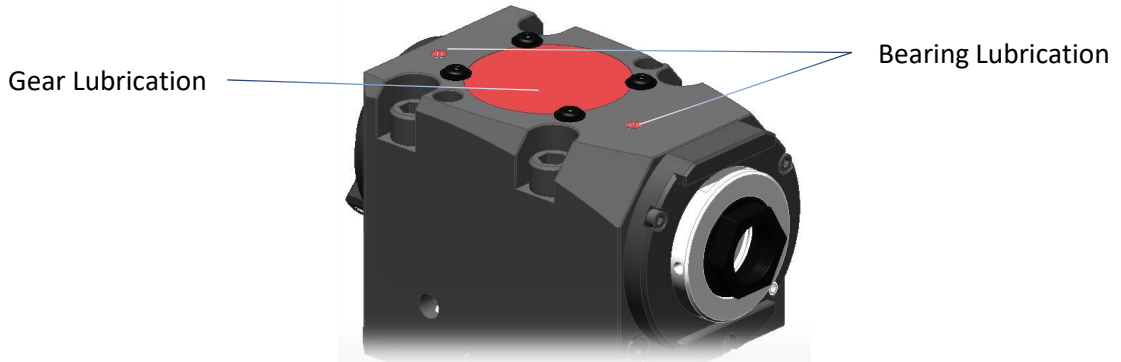

To maintain the initial performance of live toolholders, components subject to wear due to operating time (e.g. bearings and seals) must be replaced at regular intervals.

Recommended service intervals:

- **12 months** under normal operating conditions (2 shifts)
- **6 months** when operating in 3 shifts or under heavy-duty conditions
- **6 months** when using internal coolant

Maintenance, repair, or overhaul of live toolholders must be carried out only by the manufacturer or authorized service partners.

Proper use and regular preventive maintenance ensure reliable product performance. Any modification, improper handling, or misuse releases the manufacturer from any liability for damage or accidents.

6. WARRANTY

The manufacturer provides a warranty period of **12 months from the delivery date**.

The warranty covers defects in material, workmanship, and assembly.

Warranty exclusions:

The warranty does not apply in cases of:

- Improper use or negligent handling
- Unauthorized modifications or repairs
- Operation outside specified conditions
- Normal wear of components
- Failure to follow operating and maintenance instructions

Repairs under warranty must be performed exclusively by the manufacturer or authorized personnel.



The warranty becomes void if the product has been disassembled, modified, or repaired by unauthorized personnel. In such cases, the manufacturer shall be released from any liability and all warranty or service claims shall be deemed invalid.

The manufacturer further reserves the right to reject warranty claims in cases of improper use or operation outside the specified conditions.

If a warranty claim is accepted:

- The repair may include replacement of worn components
- Normal wear alone does not constitute a valid warranty claim

The manufacturer shall not be liable for:

- Design or materials provided by the customer
- Transport or storage damage
- Misuse, collisions, or improper application

All warranty claims must be submitted in writing, including a detailed and verifiable description of the defect.

6.1. Repairs outside the warranty

For toolholders no longer covered by warranty, a standard fee of EUR 30 per toolholder will be charged for disassembly and evaluation of the product condition.

If the Repair Offer is accepted by the customer and a Repair Order is issued, this fee will be waived.

7. LIMITATION OF LIABILITY

The manufacturer's liability is strictly limited to the repair or replacement of defective products, at its sole discretion.

Under no circumstances shall the manufacturer be held liable for any indirect, incidental, or consequential damages arising from the use or failure of the product.

This includes, but is not limited to:

- loss of production
- machine downtime
- loss of profit
- costs related to production interruption
- damage to other equipment or components

The customer is solely responsible for ensuring that the product is suitable for the intended application and operating conditions

8. INSPECTION AND NOTIFICATION OF DEFECTS

Upon receipt of the product, the customer must:

- inspect the packaging and product condition immediately
- report any visible defects or transport damage without delay

Any visible defects must be reported in writing within a reasonable time after delivery.

Hidden defects must be reported immediately after discovery.

Failure to notify defects within the specified time frame will result in the loss of all warranty rights.

The manufacturer reserves the right to inspect the reported defect before accepting any claim.

9. TRANSPORT RISK

All products are shipped at the customer's risk unless otherwise agreed in writing.

The risk of loss or damage passes to the customer upon dispatch of the goods from the manufacturer's premises.

Any transport damage must be:

- immediately reported to the carrier
- documented on the transport documents

Failure to report transport damage in due time may result in loss of claims against the carrier and the manufacturer.

10. USE ACCORDING TO INSTRUCTIONS

The product must be used strictly in accordance with these operating instructions and within the specified technical limits.

Improper use includes, but is not limited to:

- operation outside recommended parameters
- incorrect mounting or installation
- use of unsuitable tools or accessories
- lack of maintenance

Failure to comply with these instructions may result in:

- damage to the product
- unsafe operating conditions
- voiding of warranty claims

11. FORCE MAJEURE

The manufacturer shall not be liable for any failure or delay in fulfilling its obligations due to events beyond its reasonable control.

Such events include, but are not limited to:

- natural disasters
- fire, floods, or accidents
- strikes or labor disputes
- supply chain disruptions
- governmental restrictions or regulations

In such cases, the manufacturer is entitled to suspend or delay performance without incurring liability.

Thank you again for choosing our products!

**For further technical information, updates, and service support,
please visit our website: www.ngt-tools.ro**

For any inquiries or assistance, please contact us at:

office@ngt-tools.ro

service@ngt-tools.ro



**INNOVATIVE SOLUTIONS
FOR GREATER UTILITY.**